

**KIT PART NUMBERS 3282170 AND 6532062  
INSTRUCTIONS FOR INSTALLING AN AUTO DOOR KIT**

**CHECK THE PARTS RECEIVED IN THE KIT WITH THE PARTS LIST IN THESE INSTRUCTIONS. IF ANY PARTS ARE MISSING, CONTACT THE NATIONAL VENDORS PARTS DEPARTMENT IMMEDIATELY.**

**Read these instructions carefully before installing the kit.  
Keep these instructions for part numbers and for future reference.**

**TOOLS REQUIRED**

*Socket wrench with 3" extension and 1/4" socket  
Standard screwdriver  
Power drill with #29 (.136) drill bit  
Q-tip or disposable brush grease applicator*

**TABLE: 1**

<b>KIT PART NUMBER</b>	<b>MODEL NUMBER</b>
3282170	327 & 328 MACHINES
6532062	630, 631, 634, 636, 638, 639, 652, 653, 655, 657, 670, & 678 MACHINES

**This kit contains the following:**

<b>PART NUMBER</b>	<b>DESCRIPTION</b>	<b>QTY</b>	
		<b>3282170</b>	<b>6532062</b>
6532063	INSTR. INSTAL-AUTO DOOR KIT	1	1
3282028	MOTOR & BRKT ASSY-VEND DOOR	1	1
6732064	MOTOR & BRKT.ASSY.-VEND DOOR	1	1
6732060	TRACK-GEAR RACK	1	1
6732065	RACK ASSEMBLY-VEND DOOR	1	1
1451097	SCREW-#8-32X.31 HEX HD.TF-BLK.	2	2
6332053	LUBRICANT-2 CC PIPETTE	1	1

---

## Overview of the modification:

The modification kit is being offered to add or replace an Auto Door Assembly to the machine.

### **Part 1. Prepare the machine:**

1. Turn off the power switch and unplug the machine from its power source.

### **Part 2. If replacing an old Auto Door Assembly remove the following components; If adding a new Auto Door Assembly skip to Step 2 (see Figure 1):**

#### **NOTE:**

**Make note of harness routing, vend door rack location, vend door operation and vend door spring travel before disassembly.**

1. Unplug and remove the Auto Vend Door Motor Bracket Assembly, retain screws. Remove the Vend Door Rack Assembly.

#### **CAUTION:**

*Use caution when removing the Vend Door from the Vend Door Spring in Step 2. The Vend Door Spring is under tension and the edges can be very sharp if it suddenly retracts through your fingers.*

2. Remove the Vend Door Stop and remove the Vend Door from the return spring. Retain the Vend Door Stop and Vend Door for reassembly later. Remove the Gear Rack Track and the Vend Door Track, retain screws.
3. It is not necessary to remove the Vend Door Spring Assembly.

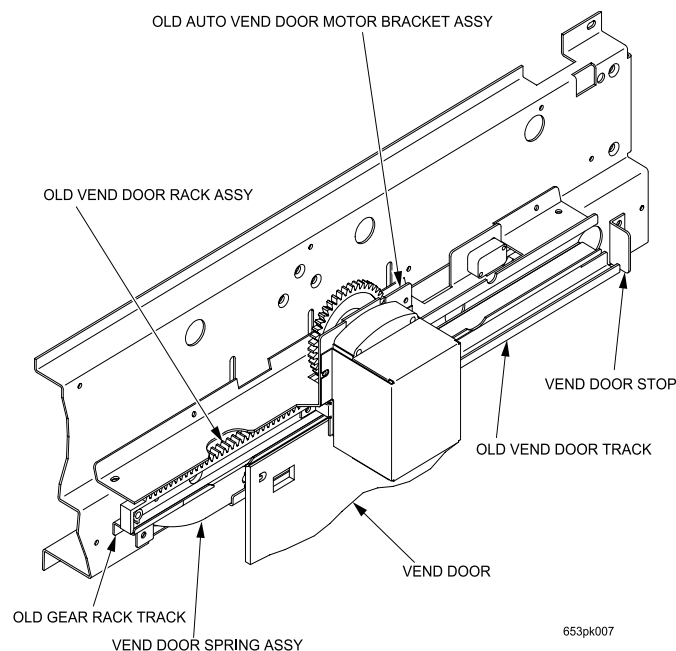
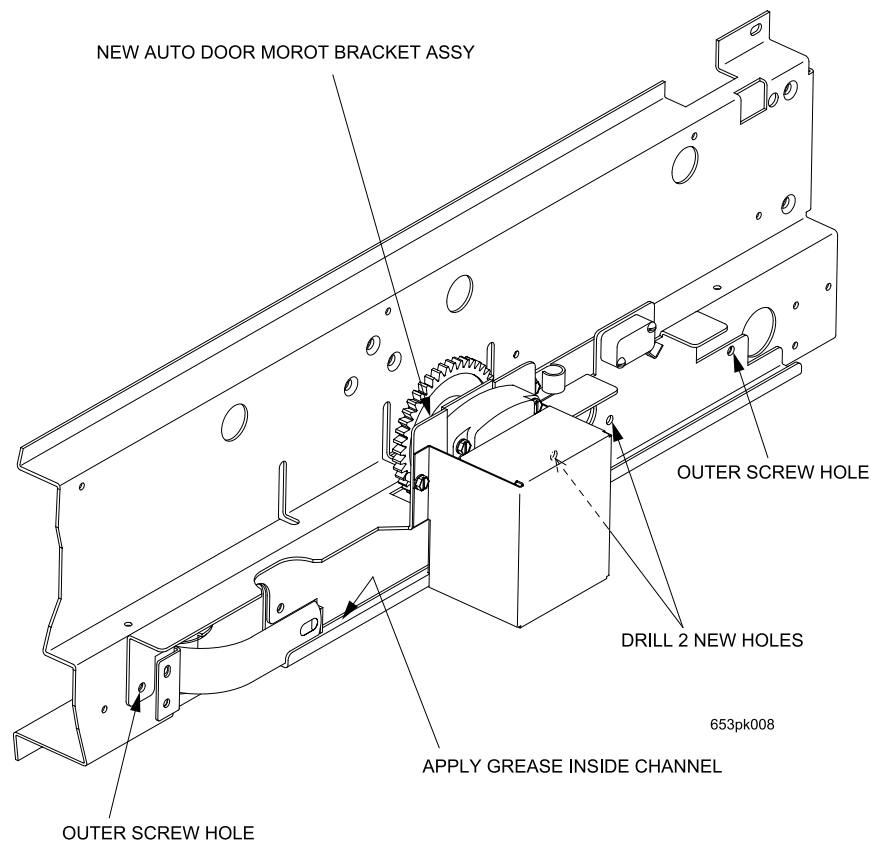

**Figure 1.**

---

### Part 3. Installing the Auto Door Assembly Kit (see Figure 2 & 3):

1. Attach the new Auto Door Motor Bracket Assembly to the door channel using screws from above step in the two outer holes as shown in Figure 2.
2. Using new bracket as a guide drill two new .136 diameter holes into the door weldment brace as noted in Figure 2. Blow out all drill shavings from the new door channel below holes and place two new 1451097 screws into the two new holes. Remove the two screws from step 1 above.
3. Apply grease to the vend door channel of the new Auto Door Motor Bracket Assembly, as noted in Figure 2.



**Figure 2.**

4. Replace Vend Door onto the Vend Door Spring and hang Vend Door in the Vend Door Channel of the new Auto Door Bracket Assembly as shown in Figure 3.
5. Apply grease to bottom of new Vend Door Rack Assembly, and install new Gear Rack Track using three screws. Make sure of proper Gear to Rack engagement and proper location of Vend Door Rack Assembly for timing of door as shown in Figure 3.
6. Connect new harness to plug and route the harness as before to keep it away from vend door travel path. Replace the Vend Door Stop.
7. Plug in the machine to the power source and turn on the power switch. Run door test through the keypad to test Vend Door for proper movement. Adjust Door Stop (if necessary) to prevent door kick out and early closing at full open position.

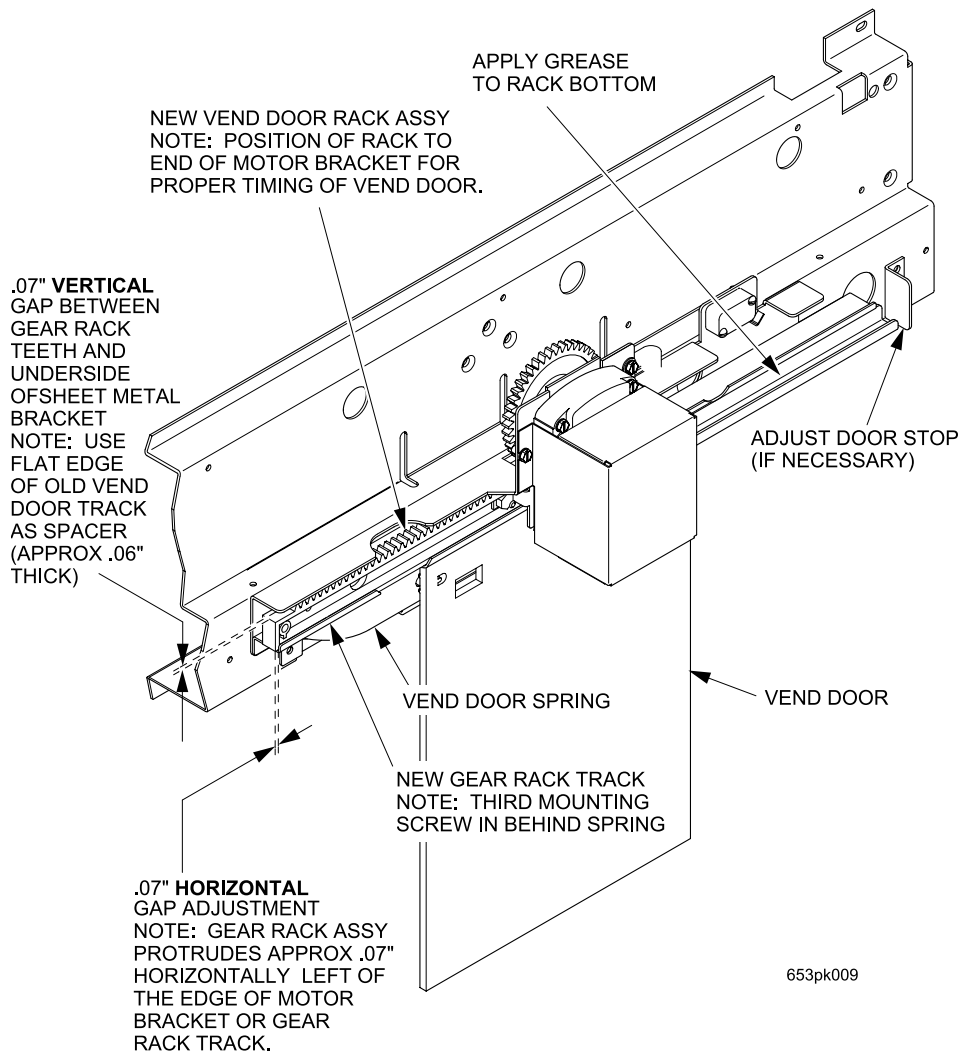

**Figure 3.**

**Part 3. Return the machine to service:**

1. Close and lock machine door.
2. The modification procedure is now complete.